

# Svalbard-I Comfort

Chilled beam with integrated VAV-function

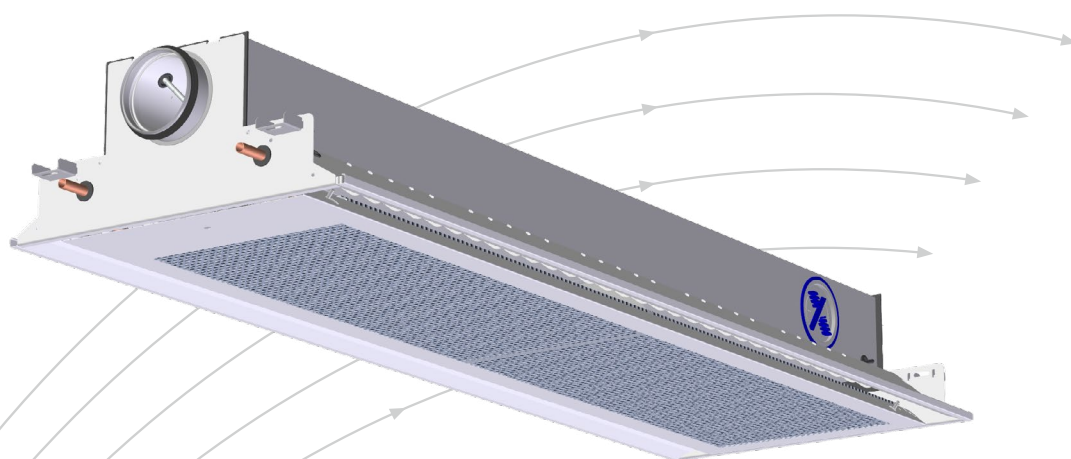

epd

NEPD-6317-5577

- Ceiling-integrated installation
- Available in 1200 mm to 3000 mm lengths
- Pressure independent VAV-function integrated
- Constant induction factor secured by integrated controller
- Bluetooth communication and app for commissioning and service
- Design and dimensioning by AURASIM



# TROX

TROX Auranor AS

Auranorvegen 6  
NO-2770 Jaren

Telephone +47 61 31 35 00

e-mail: [office-no@troxgroup.com](mailto:office-no@troxgroup.com)  
[www.trox.no/en](http://www.trox.no/en)

# Svalbard-I Comfort

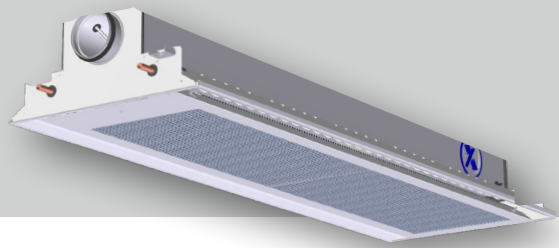

## APPLICATION

Svalbard-I Comfort is a hydronic cooling, heating and ventilation system for use in offices, shops, schools etc. The system is designed to provide a draft-free cooling effect in the occupied zone. Svalbard-I Comfort is suitable for integration in a ceiling grid with 600 mm modules.

## FUNCTION

Air is supplied via nozzles, and indoor air is extracted and fed through the coil. Effective mixing of indoor air and supply air, i.e. induction, minimises the risk of draft in the occupied zone. When Svalbard-I Comfort is used for heating, the same technique is used for dispersion of heat along the ceiling. Svalbard-I Comfort has an integrated and pressure independent VAV-damper, which controls the primary air volume to the requested setpoint, and adjust the nozzles accordingly with a secondary actuator. The VAV-damper and nozzle opening are controlled by an integrated controller in the unit, which secures a constant nozzle velocity, independent of the primary air volume. The controller can be controlled by analogue input or Modbus RTU communication. For service and commissioning the app SvalbardBLE is used, which communicates wireless by Bluetooth. Svalbard-I Comfort can be connected to TROX X-AIRCONTROL (fig. 3) with a RJ12 cable, and communicates then by Modbus. More information of X-AIRCONTROL can be found on our website [www.trox.no/en](http://www.trox.no/en).

## DESIGN

Svalbard-I Comfort is suited for ceiling grid system with 600 mm modules. It has integrated VAV-damper and adjustable nozzles, which is controlled by two actuators. Access to the actuators is shown in fig. 1 and fig. 2. The controlling is made by a controller placed behind the front panel. The coil for heating and cooling can be delivered in three options, standard cooling, high capacity cooling or combined cooling and heating. The perforated front panel can be folded down for cleaning of coil and easy access to actuator. The duct connection for primary air is spiro duct Ø125, and the water connection is Ø15 copper pipes. In the beam outlet the flow pattern can be adjusted by Jet Split lamellaes.

## MATERIALS AND SURFACE COATING

Svalbard-I Comfort is produced in galvanised steel, and visual parts are powder coated in RAL 9003 gloss 30. The measuring cross are aluminium, hoses and fittings are plastic. The damper has an attached polyester fabric. The coil has copper tubes and aluminium blades. The duct connection is fitted with EPDM rubber gasket.

## ACCESSORIES

Ordered separately and delivered separately.  
 Ballorex Dynamic valve. See separate product sheet.  
 Actuator for water valve: 24V, 230V, or 24V modulating 0-10V signal.  
 Transformer EasyTrafo 75 VA. See separate product sheet.  
 Transformer EasyTrafo 105 VA. See separate product sheet.  
 W= TROX TRV 2-way valve, Broen. See separate product sheet.  
 A1= Actuator 24V on/off, Broen. See separate product sheet.  
 A2= Actuator 230V on/off, Broen. See separate product sheet.

## ORDER CODE, Svalbard-I Comfort

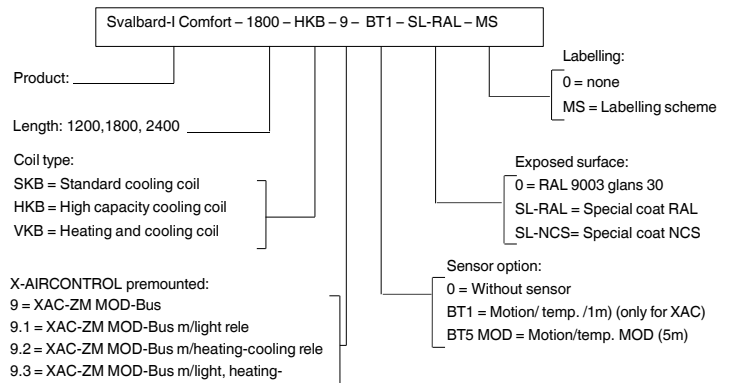

Example:  
 Svalbard-I Comfort-1800-HKB-9-BT1-SL-RAL-MS

Explanation:  
 Svalbard-I Comfort for integration in modular ceiling system, length 1800 mm, high capacity cooling coil, premounted X-AIRCONTROL module, Integrated sensor BT1, special paint and labelling scheme.

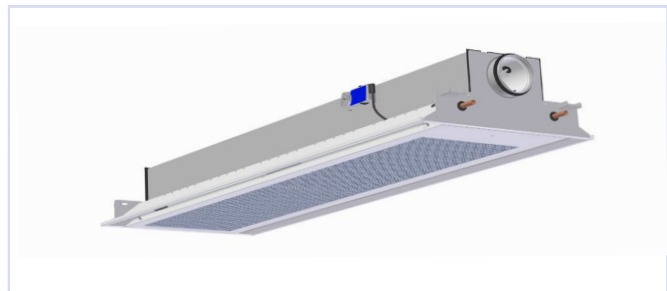

Fig. 1. Actuator

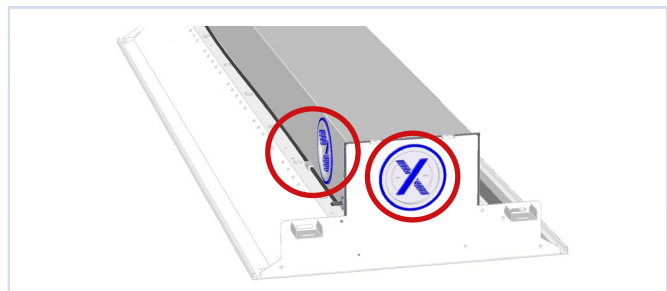

Fig. 2. Inspection hatches for nozzle opening controls

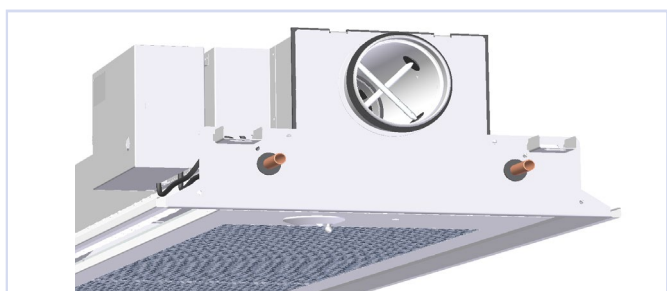
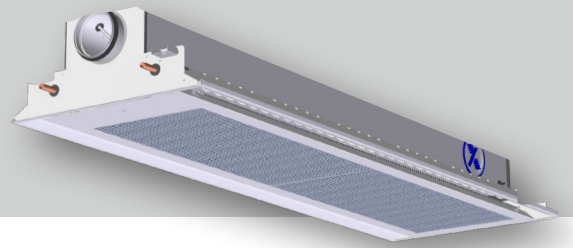

Fig. 3. Svalbard-I Comfort with XAC-ZM + X-sense premounted

# Svalbard-I Comfort



## DIMENSIONS AND WEIGHT, Svalbard-I Comfort

Length	L	L2	Weight*	Weight: water in coil [kg]		
				SKB	HKB	VKB
1200	1194	1248	21	1,0	1,3	1,3
1800	1794	1848	29	1,5	1,9	1,9
2400	2394	2348	37	2,1	2,6	2,6

Table 1. Dimension and weight (\*without water in coil)

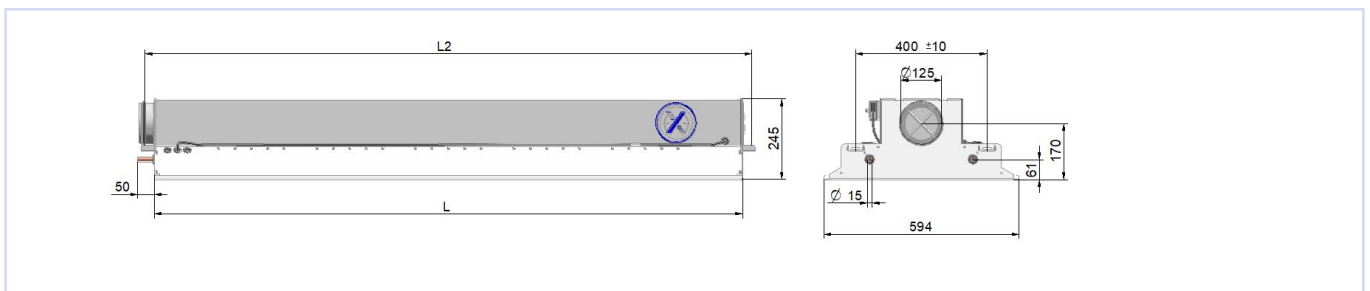

Fig. 4, Svalbard-I Comfort dimensions

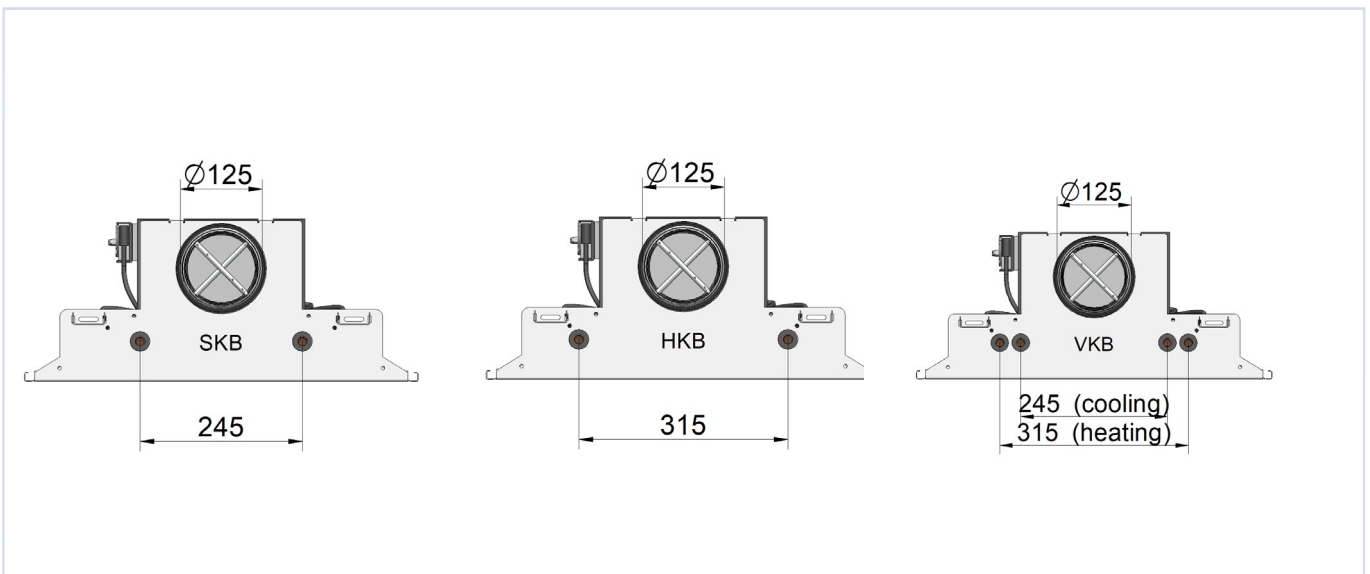

Fig. 5, connection cooling/heating

# Svalbard-I Comfort

## DIMENSIONING

Cooling- and heating capacity can be calculated by simulation tool AURASIM which can be found at [www.aurasim.no](http://www.aurasim.no)

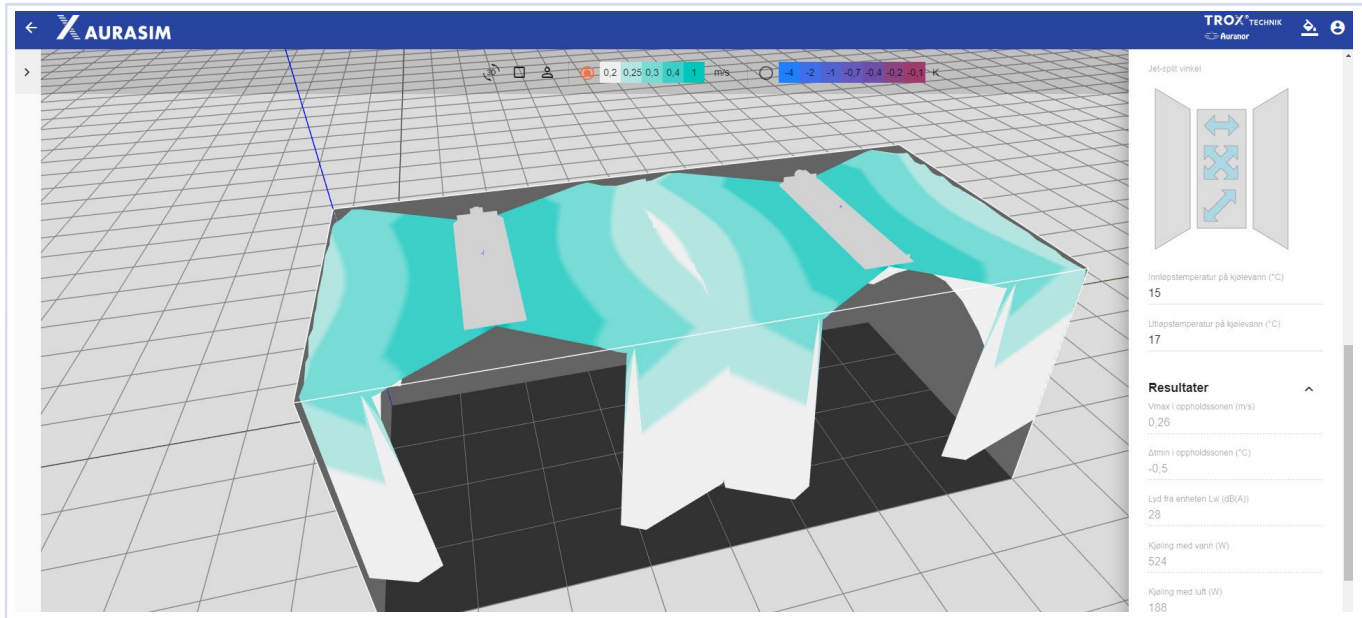

Fig. 6, AURASIM

## DIMENSIONING, COOLING CAPACITY WATER

SKB (8-pipe) and HKB (10-pipe) coil

### Svalbard-I Comfort 1200

		Cooling capacity water [W]																
Δtk [°C]		6				8				10				12				
Pt [Pa]		60		80		60		80		60		80		60		80		L <sub>WA</sub>
Coil		SKB	HKB	SKB	HKB	SKB	HKB	SKB	HKB	SKB	HKB	SKB	HKB	SKB	HKB	SKB	HKB	[dB(A)]
Air volume [m³/h]	60	311	331	345	367	430	469	458	488	545	585	571	614	658	706	671	720	21-24
	75	332	355	374	399	467	502	496	529	585	622	615	665	700	750	719	770	22-26
	90	351	375	399	429	494	532	530	565	622	655	660	715	740	792	770	825	23-29
	110	372	396	429	463	530	565	574	617	662	705	719	778	791	848	831	890	31-34

Table 2

Water volume given:  $q_w = 0,06$  l/s

Explanation: Δtk = Room temperature - middle water temperature.

### Svalbard-I Comfort 1800

		Cooling capacity water [W]																
Δtk [°C]		6				8				10				12				
Pt [Pa]		60		80		60		80		60		80		60		80		L <sub>WA</sub>
Coil		SKB	HKB	SKB	HKB	SKB	HKB	SKB	HKB	SKB	HKB	SKB	HKB	SKB	HKB	SKB	HKB	[dB(A)]
Air volume [m³/h]	90	462	498	487	525	616	661	657	705	769	825	819	877	923	988	981	1057	24-27
	110	495	535	530	568	665	715	702	760	830	895	880	945	997	1070	1060	1140	27-30
	130	530	572	565	600	711	766	745	805	888	955	940	1006	1062	1140	1130	1208	29-31
	150	564	610	597	633	754	808	796	852	945	1010	994	1063	1127	1213	1193	1274	31-35

Table 3

Water volume given:  $q_w = 0,06$  l/s

Explanation: Δtk = Room temperature - middle water temperature.

# Svalbard-I Comfort

Svalbard-I Comfort 2400

		Cooling capacity water [W]																
$\Delta t_k$ [°C]		6				8				10				12				
Pt [Pa]		60		80		60		80		60		80		60		80		$L_{WA}$
Coil		SKB	HKB	SKB	HKB	SKB	HKB	SKB	HKB	SKB	HKB	SKB	HKB	SKB	HKB	SKB	HKB	[dB(A)]
Air volume [m³/h]	90	515	555	562	604	685	743	752	806	861	922	942	1007	1030	1109	1124	1209	24-27
	110	580	628	610	658	775	835	820	880	960	1032	1020	1095	1160	1250	1220	1320	27-30
	130	645	695	665	712	860	925	890	950	1065	1145	1105	1185	1280	1385	1325	1420	29-31
	150	704	755	713	764	942	1006	954	1019	1170	1258	1194	1274	1407	1510	1426	1529	31-35

Table 4

Water volume given:  $q_w = 0,06$  l/s

Explanation:  $\Delta t_k$  = Room temperature - middle water temperature.

## FLOW PATTERN, Svalbard-I Comfort

The flow pattern can be adjusted by Jet Split, and this can be visualized by simulation tool AURASIM.

[www.aurasim.no](http://www.aurasim.no)

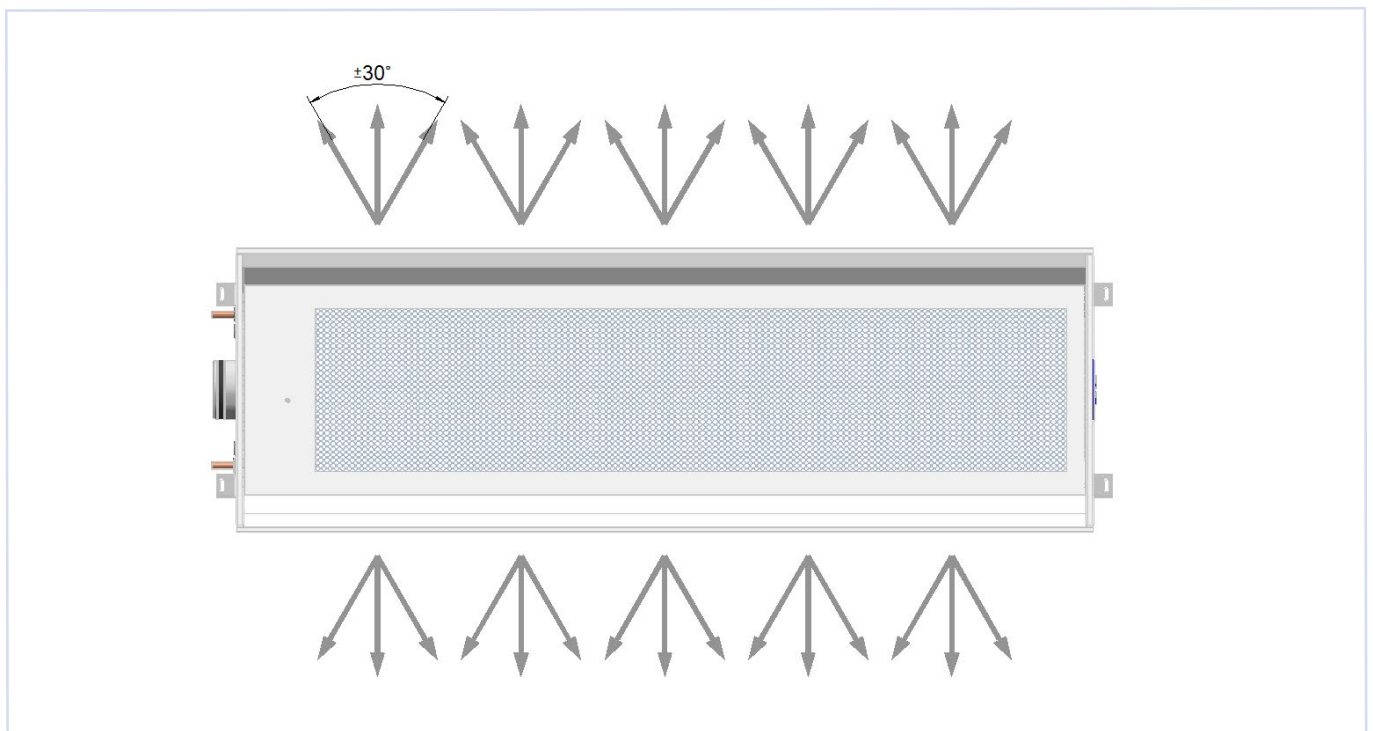

Fig. 7, flow pattern

## Svalbard-I Comfort

### INSTALLATION

Svalbard-I Comfort is supplied with four mounting brackets that is attached to the baffles short ends, by hooking brackets into the rectangular slits in the gables. See Figure 8 and 9. You have possibility of adjustment +/- 10 mm in the baffle width direction, and vertically by means of threaded rod. Use of anchor or similar is recommended when mounting on a concrete base.

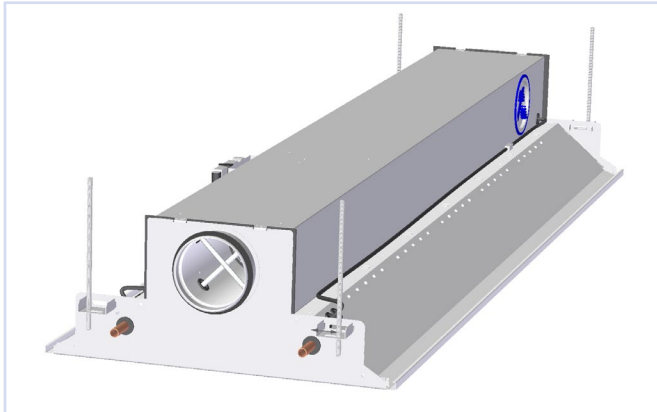

Fig. 9, Svalbard-I Comfort, installation

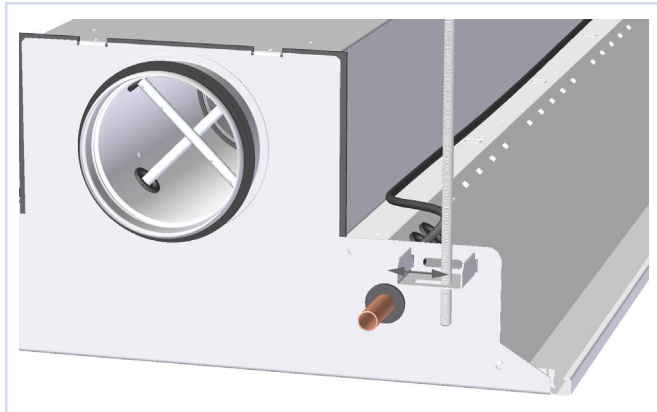

Fig. 10, Svalbard-I Comfort, installation

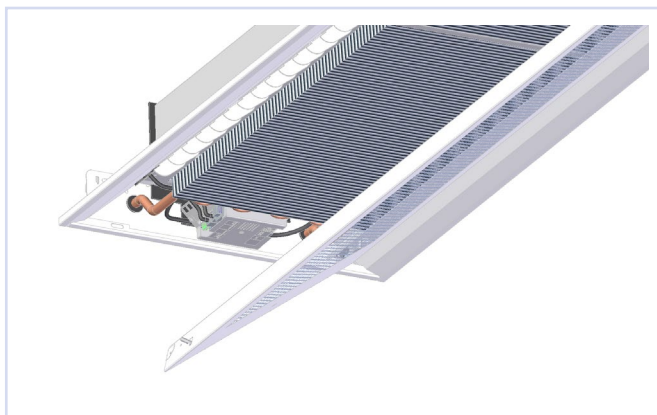

Fig. 11, Svalbard-I Comfort, maintenance

### INSTALLATION, WATER VALVE

The cooling coil in Svalbard-I Comfort is independent of water flow direction, in/out connection is optional.

### COMMISSIONING

Commissioning of Svalbard-I Comfort is easy with SvalbardBLE app, which can be downloaded free of charge from Google Play. SvalbardBLE communicate wireless by Bluetooth with the controller in Svalbard-I Comfort. Air volume settings, pressure setpoint and Modbus parametres is set easily by the app. Work area 40-150 Pa.

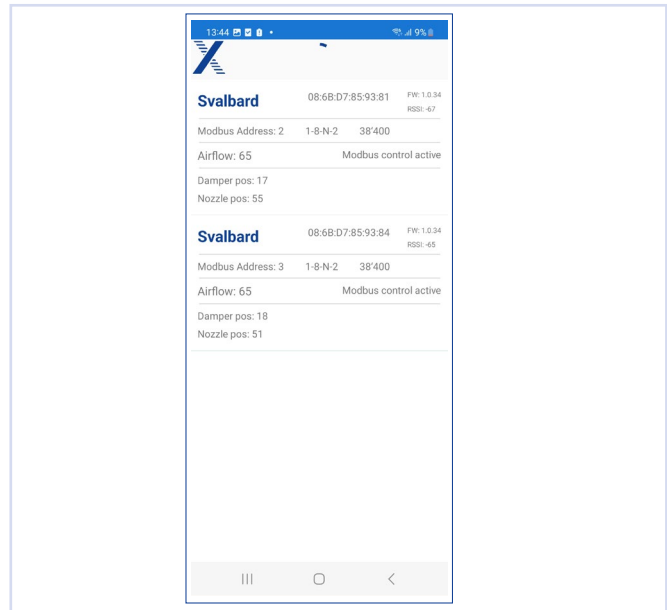

Fig. 11, SvalbardBLE  
(when updating the app, press X, PIN code:1703)

The water valve is regulated by turning the disc, which is numbered 1-10, with the current value against the groove in the threads. KVS/KV can be found in data sheet Trox TRV-2veis ventil\_KV-values, which can be found under Accessories cooling baffle. KVS is the amount of water (here stated in l/h) that flows through the valve at a pressure drop of 1 bar and with the valve fully open in the various positions. The KVS values apply without a mounted actuator. When the actuator is fitted, the values below KV (BP2) apply.

### MAINTENANCE

Full access to the coil is achieved by folding down the front panel as shown in fig. 10. Vacuuming and, if required, using a damp cloth to clean the unit is recommended.

### ENVIRONMENT

Enquiries regarding product declaration can be directed to our sales team, or information can be found at our website: [www.trox.no](http://www.trox.no)

# Svalbard-I Comfort

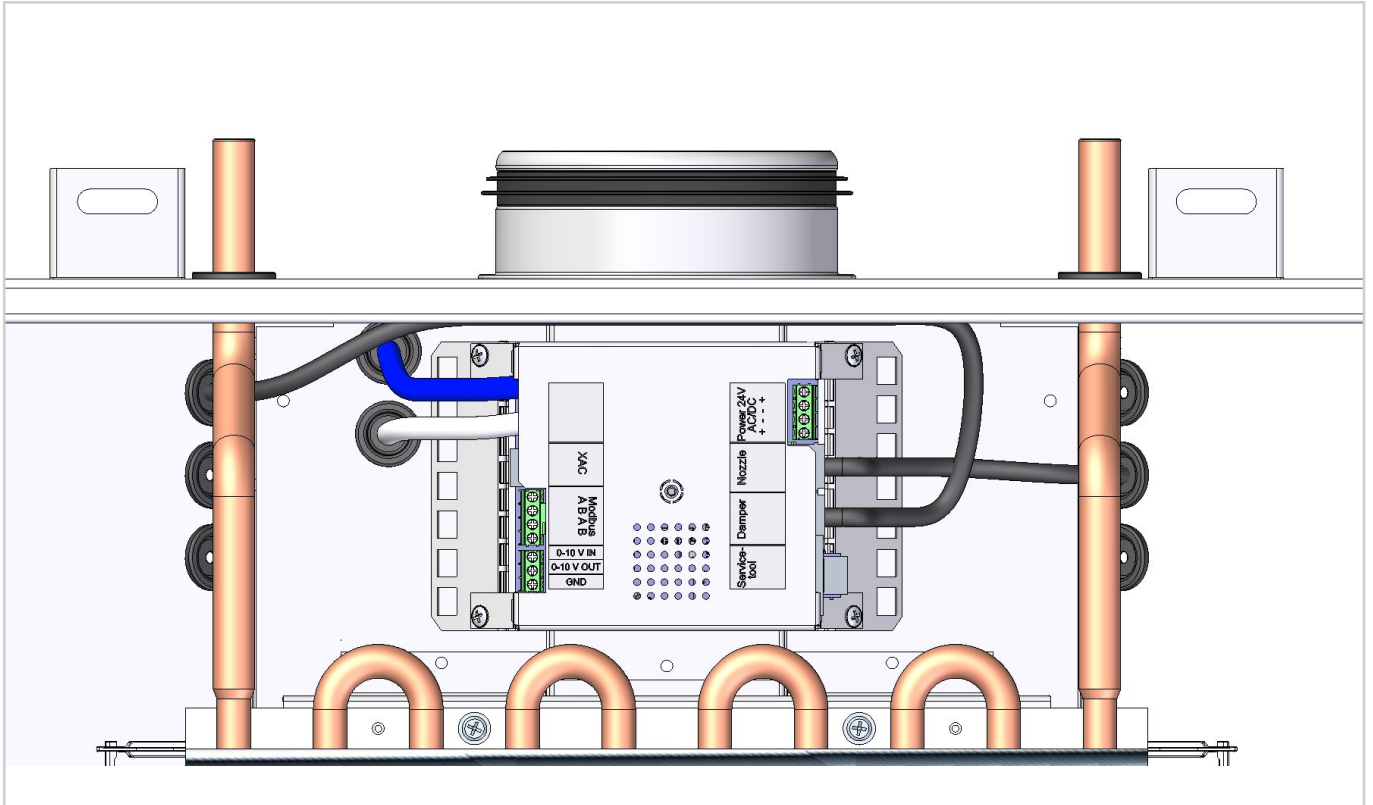

Fig.12, Regulator

## Wiring diagram

Power 24V = 24V AC/DC

Design power consumption = 3 W

Nozzle = Connection for nozzle actuator

Damper = Connection for damper actuator

Service tool = Service tool entry

XAC = Input for X-AIRCONTROL

Modbus ABAB = Input and output for modbus line

0-10V in = Input

0-10V out = Output (damper position)

GND = Common 0 for 0-10V

## Svalbard-I Comfort

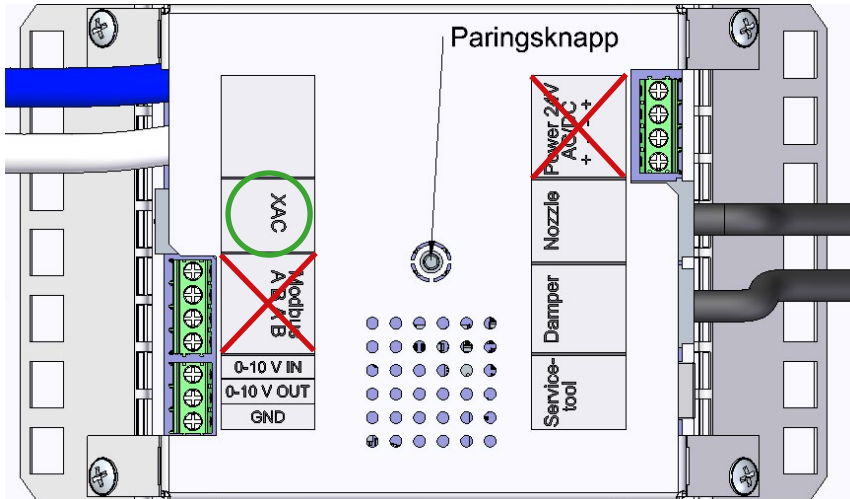

Figure 13:

NOTE: If the XAC input is in use, power 24V cannot be used at the same time. Controls then receive power from the XAC input.

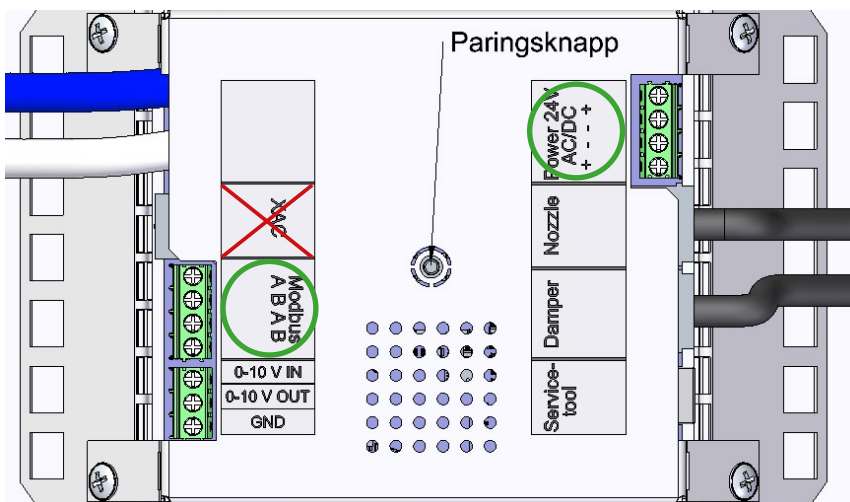

Figure 14:

NOTE: If XAC input is not connected, use terminal blocks for 24V and Modbus



# Svalbard-I Comfort

## SVALBARD MODBUSREGISTER

Svalbard-I Comfort					
Address	Description	Range Enumeration	Unit	Scaling	Access
0	Setpoint% between Min (105) and Max (106)	0...10000 (Default: 0)	%	0.01	R / W
1	Override	"0: None 1: Open 2: Close 3: Min 4: Mid 5: Max 6: Open and Nozzel set (Reg 114) Default: None(0)"	-	-	R / W
2	Command	0: None	-	-	R / W
3	Actuator Type	2: VAV / EPIV	-	-	R
4	Relative Position	0...10'000	%	0.01	R
5	Absolute Position	0...max angle / stroke	° mm	1 1	R
6	Relative volumetric flow of Vnom	0...10'000	%	0.01	R
7	Absolut volumetric flow	0...Vnom	m³/h Pa	1	R
8	Relative Position Nozzle	0...10'000	%	0.01	R
9	Average differential pressure	0...12500	Pa	0.01	R
10	Absolute volumetric flow	in unit selected (low word)	UnitSel	0.001	R
11	Absolute volumetric flow	in unit selected (high word)	UnitSel	0.001	R
12	Setpoint Analog, Shows the setpoint in % analog signal	0...10'000	%	0.01	R
13	Setpoint Nozzle (calculated)	0...100	%	1	R
99	Series Number 1st part (Same as device ID)	-	-	-	R
100	Series Number 2nd part	-	-	-	R
101	Series Number 3rd part	-	-	-	R
102	Series Number 4th part	-	-	-	R
103	Firmware Version MY/MI	"High byte: FW-Version Major Low byte: FW-Version Minor"	-	-	R
104	Malfunction and Service Information	"Bit 0 = Bus timed out Bit 1 = Button pushed"	-	-	R
105	Vmin	0...Vmax (Default: 0)	%	0.01	R / W
106	Vmax	Vmin...10'000 (Default: 10'000)	%	0.01	R / W
107	Pressure setpoint	40..150Pa (Default:50)	-	-	R / W
108	Bus Fail Position	"0: None / Last setpoint 1: close 2: open 3: 50% Default: None(0)"	-	-	R / W
109	Timeout for Bus	10...3'600 (Default: 120)	s	1	R / W
110	Nominal volumetric flow	-	m³/h	1	R
111	Firmware Version PA	"High byte: - Low byte: FW-Version Patch"	-	-	-
112	Vnom in unit selected (Register 118)	in unit selected (low word)	UnitSel	0.001	R
113	Vnom in unit selected (Register 118)	in unit selected (high word)	UnitSel	0.001	R
114	Nozzle Setpoint (If Register 2 equal 6)	"0...100 Default: 0"	%	-	R / W
115	Product size	"1: 1200 2: 1800 3: 2400"	mm	-	R / W
116	Control Mode	1: Flow control	-	-	R

# Svalbard-I Comfort

## SVALBARD MODBUSREGISTER

Svalbard-I Comfort					
Address	Description	Range Enumeration	Unit	Scaling	Access
117	Unit Selection Flow	"0: m³/s 1: m³/h 2: l/s 3: l/min 4: l/h 5: gpm 6: cfm Default: m³/h(1)"	-	-	R / W
118	Setpoint Source	"0: Analog 1: Bus 2: Bluetooth Default: Bus(1)"	-	-	R / W
119	Modbus Address	1...247	-	-	R / W
120	Transmission Format	"0: 1-8-N-2 1: 1-8-N-1 2: 1-8-E-1 3: 1-8-O-1 Default: 1-8-N-2"	-	-	R / W
121	Baud Rate	"0: 9'600 1: 19'200 2: 38'400 3: 76'800 4: 115'200 Default: 38400"	-	-	R / W